

Small Animal Image Guided Irradiation System

Advances in our understanding of the molecular biology of cancer, combined with rapid technological advances in radiation therapy targeting and delivery are emphasizing the need for greater capacity to study radiation effects in complex systems.

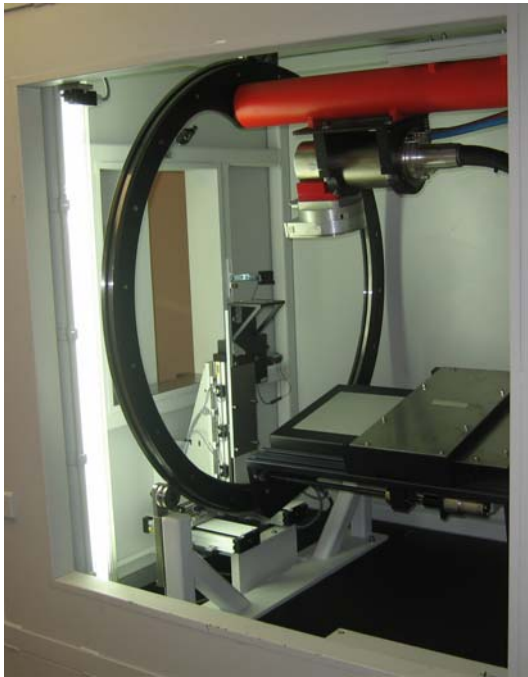

The **X-RAD 225 Cx** provides image-guided placement of irradiation distributions within pre-clinical subjects.

The isocentric design, combined with an amorphous silicon flat-panel detector, permits high-performance cone-beam CT soft-tissue imaging of the subject *in situ* prior to irradiation.

The cross-calibration of imaging and treatment isocenters allows targeting of the radiation field through three-dimensional (3D) translation of the subject to align target or avoid normal structures.

Typically setup, imaging, guidance and irradiation time is completed in 15 minutes for single isocenters and reasonable doses (<10 Gy).

The compact rotational gantry is housed within a self-shielded assembly and controlled by a Windows XP application.

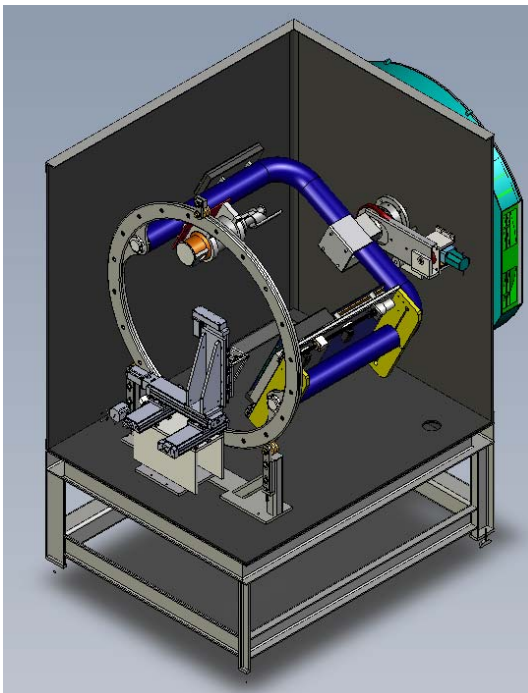

Technical Specifications

Irradiation Performance:

Irradiation Energy: 50-225 kVp (nominal)
Dose Rate: 10-400 cGy/min
Filtration: Interchangeable slides (2) HVL's provided (additional values available)
Collimation: Interchangeable, fixed aperture, optional cones available from 1mm to 20cm
Beam Orientation: Fixed, Dynamic (0 - 360°)
IG Targeting Precision (unambiguous targets): +/- 0.5 mm
Maximum Dose Gradient (d_{80-20}): 0.2 mm

Imaging Performance:

Volumetric Imaging Resolution: 0.2 mm (nominal)
Volumetric Field of View: 100 mm diameter cylinder of 100 mm length
Minimum Acquisition Time: 20 seconds
CT Noise: 50 HU at 0.2 mm voxel resolution
Geometric Linearity: 0.5 mm over 100 mm
Typical Imaging Dose: 1-10 cGy (center of 30 mm subject)



Supplied Collimator Set

System Components:

X-Ray Unit:

Power Supply: GE ISOVOLT TITAN 225kV, 4500 Watt Power Supply
X-Ray Tube: Comet MXR 225/22 metal ceramic, dual filament design.
Power: (640W / 3000 W) Focal spot: (d=1mm / d=5.5mm)

Imaging Panel:

Perkin Elmer XRD 0820 AN3-ES
Active pixels: (1024 x 1024)
Pitch: 200 μ m
Total Area: 20 cm x 20 cm
Capture Speed: 15 fps (30 fps with 2x2 binning)

Imaging Software Platform:

Pilot V1.1: Image Acquisition and Reconstruction & 3D Alignment and Targeting Software (Developed in collaboration with The University of Toronto)
Excel® based Irradiation Time Calculator
Capacity for Image Storage
Tools provided to assist in migrating external imaging platforms onto this system.
Pentium 4 Quad Core CPU
Windows XP Professional Operating System

Motion Stages:

Rotational: 0-360 degrees with adjustable rotation speed (20 sec to 6 minutes)
X-Y-Z Animal Stage: Precision platform capable of positioning accuracy of better than 0.2mm

Mechanical:

Assembly Weight: 2200 kg. (5000 lbs)
Assembly Dimensions: 82"h x 72"w x 48"d (208cm h x 183cm w x 122cm d)
Heat Dissipation: 3000 Watts maximum when X-Rays ON

Electrical requirements:

1N PE 230 V \pm 10%, 50/60 Hz, 35A or 3N PE 400/230 V \pm 10%, 50/60 Hz, 25A (TN-S or TN-C-S)

Safety:

External radiation leakage limit: 1uSv/hr @ 10cm
Cabinet X-Ray system complies with US Regulations 21 CFR 1020.40